

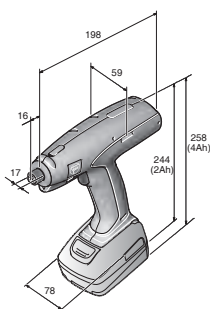

		SGA %i- D7.. nWnUj ai UrdU	SGA %i- D7.. nWnUj ai UrdU	SGA %i- D7.. nWnUj ai UrdU	SGA %i- D7.. nWnUj ai UrdU	SGA %i- D7.. nWnUj ai UrdU	SGA %i- D7.. nWnUj ai UrdU	SGA %i- D7.. nWnUj ai UrdU	SGA %i- D7.. nWnUj ai UrdU
		K_f M_U VmWg ckUu kVgY[bdfa :- z' J8# 89- (+z kgUjVtdj] 7A? 2%+ dirm+ %- fk odNV/ c* gJalU'	K_f M_U VmWg ckUu kVgY[bdfa :- z' J8# J89- (+z kgUjVtdj] 7A? 2%+ dirm+ %- fk odNV/ c* gJalU'	Dc[flackU Ek_f M_U VmWg ckUu nac]kc VV VmWg UY k[:- z' J8# J89- (-'	K_f M_U VmWg ckUu Ek_f M_U VmWg ckUu kVgY[bdfa :- z' J8# J89- (+z kgUjVtdj] 7A? 2%+ dirm+ %- fk odNV/ c* gJalU'	Dc[flackU Ek_f M_U VmWg ckUu nac]kc VV VmWg UY k[:- z' J8# J89- (+z kgUjVtdj] 7A? 2%+ dirm+ %- fk odNV/ c* gJalU'	K_f M_U VmWg ckUu Ek_f M_U VmWg ckUu kVgY[bdfa :- z' J8# J89- (+z kgUjVtdj] 7A? 2%+ dirm+ %- fk odNV/ c* gJalU'	Dc[flackU Ek_f M_U VmWg ckUu nac]kc VV VmWg UY k[:- z' J8# J89- (+z kgUjVtdj] 7A? 2%+ dirm+ %- fk odNV/ c* gJalU'	Dc[flackU Ek_f M_U VmWg ckUu nac]kc VV VmWg UY k[:- z' J8# J89- (+z kgUjVtdj] 7A? 2%+ dirm+ %- fk odNV/ c* gJalU'
GfcbU		&	&	&	&	' \$	' \$	' \$	' \$
SUBVWwUjUby	NjVgaca Vdi cMidekV[c flaE	\$!&	\$!&	%-*	%-*	\$-	\$-	'!&	'!&
	D X_c cMidekUjMj UjK[Vc flaf#]E	(') \$) \$ (+) \$	* \$) \$ %- \$	* \$) \$ (+) \$) \$) \$ (+) \$
	BUj VVdE	%-	%-	%-	%-	%-	%-	%-	%-
	I Wkrhdun XjU	%- K_f h n[duKla gV V- Hra	%- K_f h n[duKla gV V- Hra	%- K_f h n[duKla gV V- Hra	%- K_f h n[duKla gV V- Hra	%- K_f h n[duKla gV V- Hra	%- K_f h n[duKla gV V- Hra	%- K_f h n[duKla gV V- Hra	%- K_f h n[duKla gV V- Hra



5GA %(!&fWnUj ai Uetck

K_f M_UVWmckUBkVg[bcfa :cC)' -' ZjS# 89# (+zkgUjVhbq_7A? 2%+dimr %@ Tk cdUj/c* g'atE'



5_VlgfJzdUingidU)

Zakres momentu obrotowego	Ba	\$-! &
Df X_c c'fidekUMjI' t'jkVc	c'f#b)j)\$!&)
Buq V	J	%z
I Wkrhdln XjU		%K_f ln[h]UkA gV Vh. ltra
Bi a Yf rLa cE]YbJU		+%%*\$\$\$-) \$
95B		(%) , , %&(-
7YbUbyHc fWnJ 5H:O? \$Q		8%) Z \$
7YbUVi HcK DdB O? \$Q		8+\$\$\$) -

NUYmbUfn Xj: 9B.
 'GrgVhckngj[YVjHmBnqYkraUUVh _dgykUy'
 'NlkkbUICEbcaMby]dYVWnqYXcMUYacaVdm c'idekVZ_Mi b] c'idekZ_ lUclfdhZacaVdi c'idekV[cdcdj]VWg''
 'CdraUjUMfclVg Xj]_odCB]b] dbcbk[c' kyVWg]j]rUWf]VWg] dhnXdbcbkra Fori Wla' f]cdhcUj ai UetE'
 '5 jnkUWc'idek k 'kcdnVhUq] V]dntqj''
 'HWbc[U]ekd'ebckUWkUj]_g_]W' cdMUy bUWtra b]jckUj Uj ai UetU'
 'Oj]d X_c c'idekUc'gahY[c'krjVg]U' Oj]c k]Hq]Ya]YgUk_f Vg]U' '8ck_f Vg]Ja]]_]c]HkUW[c' U]c'knfori W' '7]WkrjVg]U'

5GA %(!&D7 fWnUj ai Uetck

K_f M_UVWmckUBkVg[bcfa :cC)' -' ZjS# 89# (+zkgUjVhbq_7A? 2%+dimr %@ Tk cdUj/c* g'atE'



5_VlgfJzdUingidU)

Nj]fjaca Vdi c'fidekV[c	Ba	\$-! &
Df X_c c'fidekUMjI' t'jkVc	c'f#b)j)\$!&)
Buq V	J	%z
I Wkrhdln XjU		%K_f ln[h]UkA gV Vh. ltra
Bi a Yf rLa cE]YbJU		+%%*\$\$\$-) \$
95B		4014586881317
Cena netto (bez VAT) [PK 05]		2.723,60
Cena brutto w PLN [PK 05]		3.350,03

NUYmbUfn Xj: 9B.
 'GrgVhckngj[YVjHmBnqYkraUUVh _dgykUy'
 'Ac]kc n'fcd[ruckUj]dUlaVICE.df X_c V' c'idekVZ_Mi b] c'idekZ_ lUclfdhZacaVdi c'idekV[cdcdj]VWg''
 'CdraUjUMfclVg k d] V'_fc_UWd[c'rbi' i gnk]brn]p]h]Uj]V]c]Uj]b]V]g]Uy' 'I gnk]b]_f]r]U]X]C] k]p]i V]a' ac]kc 'a]b]i U]Y' 'HWbc[U]ekd'ebckUWkUj]_g_]W' cdMUy bUWtra b]jckUj Uj ai UetU'
 'Ack y]k]p]k]n]M]Uk_f V]b]k_f ln]r]d]Y d]la V]n]U]Uy' 'UkYkdc[U]U]V]U]n]M]d]n]_cad P]' 'Grg]V]b]d]c[ruckUj]i fn X]h]U]b]d]n]i r]h]f]ck]b]r]y]V' 'N]d]h]U]d]U]la V]ICE' '8ck_f Vg]Ja]]_]c]HkUW[c' '8U_g]U]j c'idek'cb]W]k_f Vg]U]j]_g]m]ck]U]j' 'W]t]Ja'' : U]n]b]V]r]U]W]f]V]W]g]U]l]Ja'' 'Ack]n]j ai Uet]ekd'ebckn]V]kg]U]j]Na' b]jckUj

5GA %(!* fWnUj ai Uetck

K_f M_UVWmckUBkVg[bcfa :cC)' -' ZjS# 89# (+zkgUjVhbq_7A? 2%+dimr %@ Tk cdUj/c* g'atE'



5_VlgfJzdUingidU)

Nj]fjaca Vdi c'fidekV[c	Ba	%z*
Df X_c c'fidekUMjI' t'jkVc	c'f#b)j	600
Buq V	J	%z
I Wkrhdln XjU		%K_f ln[h]UkA gV Vh. ltra
Numer zamówienia		7 112 28 00 95 0
95B		(%) , , * & ,
7YbUbyHc fWnJ 5H:O? \$Q		8%) Z \$
7YbUVi HcK DdB O? \$Q		8+\$\$\$) -

NUYmbUfn Xj: 9B.
 'GrgVhckngj[YVjHmBnqYkraUUVh _dgykUy'
 'NlkkbUICEbcaMby]dYVWnqYXcMUYacaVdm c'idekVZ_Mi b] c'idekZ_ lUclfdhZacaVdi c'idekV[cdcdj]VWg''
 'CdraUjUMfclVg Xj]_odCB]b] dbcbk[c' kyVWg]j]rUWf]VWg] dhnXdbcbkra Fori Wla' f]cdhcUj ai UetE'
 '5 jnkUWc'idek k 'kcdnVhUq] V]dntqj''
 'HWbc[U]ekd'ebckUWkUj]_g_]W' cdMUy bUWtra b]jckUj Uj ai UetU'
 'Oj]d X_c c'idekUc'gahY[c'krjVg]U' Oj]c k]Hq]Ya]YgUk_f Vg]U' '8ck_f Vg]Ja]]_]c]HkUW[c' U]c'knfori W' '7]WkrjVg]U'

5GA %(!* D7 fWnUj ai Uetck

Df[ruckUBk_f M_Uhac]kc V]V]W]m]U]k[:cC)' -' ZjS# 89# (+'



5_VlgfJzdUingidU)

Nj]fjaca Vdi c'fidekV[c	Ba	%z*
Df X_c c'fidekUMjI' t'jkVc	c'f#b)j)\$%\$\$\$
Buq V	J	%z
I Wkrhdln XjU		%K_f ln[h]UkA gV Vh. ltra
Bi a Yf rLa cE]YbJU		+%%)(\$\$-) \$
95B		(%) , , +(8%&
7YbUbyHc fWnJ 5H:O? \$Q		8+8 Z \$
7YbUVi HcK DdB O? \$Q		'")\$8\$

NUYmbUfn Xj: 9B.
 'GrgVhckngj[YVjHmBnqYkraUUVh _dgykUy'
 'Ac]kc n'fcd[ruckUj]dUlaVICE.df X_c V' c'idekVZ_Mi b] c'idekZ_ lUclfdhZacaVdi c'idekV[cdcdj]VWg''
 'CdraUjUMfclVg k d] V'_fc_UWd[c'rbi' i gnk]brn]p]h]Uj]V]c]Uj]b]V]g]Uy' 'I gnk]b]_f]r]U]X]C] k]p]i V]a' ac]kc 'a]b]i U]Y' 'HWbc[U]ekd'ebckUWkUj]_g_]W' cdMUy bUWtra b]jckUj Uj ai UetU'
 'Ack y]k]p]k]n]M]Uk_f V]b]k_f ln]r]d]Y d]la V]n]U]Uy' 'UkYkdc[U]U]V]U]n]M]d]n]_cad P]' 'Grg]V]b]d]c[ruckUj]i fn X]h]U]b]d]n]i r]h]f]ck]b]r]y]V' 'N]d]h]U]d]U]la V]ICE' '8ck_f Vg]Ja]]_]c]HkUW[c' '8U_g]U]j c'idek'cb]W]k_f Vg]U]j]_g]m]ck]U]j' 'W]t]Ja'' : U]n]b]V]r]U]W]f]V]W]g]U]l]Ja'' 'Ack]n]j ai Uet]ekd'ebckn]V]kg]U]j]Na' b]jckUj

5GA 9B 5771 H7 ai Ucfk



5_VlgfJzdUingidU

K_f M_UVhndkUBkVg[bcfa :CC) -' zj 8# 89# (+zkgQjmbj 7A? 2% +dimn % ik cdU/c* g'auE'

Zakres momentu obrotowego	Ba	8-
Df Xc c'fidekUMi' t' yjkVc	c'f#b	*\$\$
BuV W	J	%Z
I Wkrhdln XjU		%K_f Hn[h]Uka gV Vh Hra
Bi a Yf rLb CE]YbU		+%%)- \$\$-) \$
9SB		4014586877211
Cena netto (bez VAT) [PK 05]		2.195,60
Cena brutto w PLN [PK 05]		2.700,59

- NUYmbLfn Xj: 9B.**
- ▶ Bezszcotkowy silnik elektryczny nie wymagający konserwacji.
 - ▶ Zapewnia równomierne i precyzyjnie dobrane momenty obrotowe niezależnie od rodzaju wkręcania.
 - ▶ Optymalizacja procesu dzięki opóźnieniu ponownego włączenia i zabezpieczeniu przed ponownym rozruchem (kontrola akumulatora).
 - ▶ Aktywacja obrotów w lewo przez naciśnięcie przycisku.
 - ▶ Technologia litowo-jonowa zapewnia większą liczbę operacji na jednym naładowaniu akumulatora.
 - ▶ Stała prędkość obrotowa do samego wyłączenia.
 - ▶ Stałe oświetlenie miejsca wkręcania.
 - ▶ Do wkręcania miękkiego i twardego.
 - ▶ Łagodny rozruch.
 - ▶ Ciche wyłączenie.

ASM 14-9 PC (bez akumulatora)



5_VlgfJzdUingidU

Dc[rLackUBk_f M_Uhac]kc V[Vhndk U]k[:CC) -' zj 8# 89# (+zkgQjmbj 7A? 2% +dimn % ik cdU/c* g'auE'

NjVgaca Vh c'fidekVc	Ba	8-
Df Xc c'fidekUMi' t' yjkVc	c'f#b)\$+) \$
BuV W	J	%Z
I Wkrhdln XjU		%K_f Hn[h]Uka gV Vh Hra
Bi a Yf rLb CE]YbU		+%%)) \$\$-) \$
9SB		(\$%), *, +(%)
7YbUbyHc rVhNj 5H:O? \$)Q		8+8 Z \$
7YbUVi Hc k D8B O? \$)Q		") \$8\$

- NUYmbLfn Xj: 9B.**
- ▶ Ergonomiczny kształt i wyważenie zapewniają wygodną pracę i precyzyjne dobrane momenty obrotowe niezależnie od rodzaju wkręcania.
 - ▶ Optymalizacja procesu dzięki opóźnieniu ponownego włączenia i zabezpieczeniu przed ponownym rozruchem (kontrola akumulatora).
 - ▶ Aktywacja obrotów w lewo przez naciśnięcie przycisku.
 - ▶ Technologia litowo-jonowa zapewnia większą liczbę operacji na jednym naładowaniu akumulatora.
 - ▶ Stała prędkość obrotowa do samego wyłączenia.
 - ▶ Stałe oświetlenie miejsca wkręcania.
 - ▶ Do wkręcania miękkiego i twardego.
 - ▶ Łagodny rozruch.
 - ▶ Ciche wyłączenie.

5GA 9B 5771 H7 ai Ucfk



5_VlgfJzdUingidU

K_f M_UVhndkUBkVg[bcfa :CC) -' zj 8# 89# (+zkgQjmbj 7A? 2% +dimn % ik cdU/c* g'auE'

NjVgaca Vh c'fidekVc	Ba	'!%&
Df Xc c'fidekUMi' t' yjkVc	c'f#b)\$\$
BuV W	J	%Z
I Wkrhdln XjU		%K_f Hn[h]Uka gV Vh Hra
Bi a Yf rLb CE]YbU		+%%)+ \$\$-) \$
9SB		(\$%), *, +%,
7YbUbyHc rVhNj 5H:O? \$)Q		8% Z \$
7YbUVi Hc k D8B O? \$)Q		8+8\$) -

- Zalety narzędzi FEIN:**
- ▶ Ergonomiczny kształt i wyważenie zapewniają wygodną pracę i precyzyjne dobrane momenty obrotowe niezależnie od rodzaju wkręcania.
 - ▶ Optymalizacja procesu dzięki opóźnieniu ponownego włączenia i zabezpieczeniu przed ponownym rozruchem (kontrola akumulatora).
 - ▶ Aktywacja obrotów w lewo przez naciśnięcie przycisku.
 - ▶ Technologia litowo-jonowa zapewnia większą liczbę operacji na jednym naładowaniu akumulatora.
 - ▶ Stała prędkość obrotowa do samego wyłączenia.
 - ▶ Stałe oświetlenie miejsca wkręcania.
 - ▶ Do wkręcania miękkiego i twardego.
 - ▶ Łagodny rozruch.
 - ▶ Ciche wyłączenie.

ASM 14-12 PC (bez akumulatora)



5_VlgfJzdUingidU

Dc[rLackUBk_f M_Uhac]kc V[Vhndk U]k[:CC) -' zj 8# 89# (+zkgQjmbj 7A? 2% +dimn % ik cdU/c* g'auE'

NjVgaca Vh c'fidekVc	Ba	'!%&
Df Xc c'fidekUMi' t' yjkVc	c'f#b)\$+) \$
BuV W	J	%Z
I Wkrhdln XjU		%K_f Hn[h]Uka gV Vh Hra
Bi a Yf rLb CE]YbU		+%%)* \$\$-) \$
9SB		(\$%), *, +(%)
7YbUbyHc rVhNj 5H:O? \$)Q		8+8 Z \$
7YbUVi Hc k D8B O? \$)Q		") \$8\$

- NUYmbLfn Xj: 9B.**
- ▶ Ergonomiczny kształt i wyważenie zapewniają wygodną pracę i precyzyjne dobrane momenty obrotowe niezależnie od rodzaju wkręcania.
 - ▶ Optymalizacja procesu dzięki opóźnieniu ponownego włączenia i zabezpieczeniu przed ponownym rozruchem (kontrola akumulatora).
 - ▶ Aktywacja obrotów w lewo przez naciśnięcie przycisku.
 - ▶ Technologia litowo-jonowa zapewnia większą liczbę operacji na jednym naładowaniu akumulatora.
 - ▶ Stała prędkość obrotowa do samego wyłączenia.
 - ▶ Stałe oświetlenie miejsca wkręcania.
 - ▶ Do wkręcania miękkiego i twardego.
 - ▶ Łagodny rozruch.
 - ▶ Ciche wyłączenie.



		SGK %1*	SGK %1*	SGK %1*	SGK %1* D7	SGK %1* D7	SGK %1* D7	SGK %1* D7	SGK %1* D7	SGK %1* D7	
		K_f M_UVW...ckUBkVg[bfa : (C) ' - ' zj 8# 89# (-# kgQWtdj_7A? 2% +dimh - %# ik odU/c* g'alt'			Dd[flackUBk_f M_Uhac]kc W/VWtdj_UVj[: (C) ' - ' zj 8# 89# (-#kgQWtdj_7A? 2% +dimh %# ik odU/c* g'alt'						
GfcbU		' &	' &	' &	''	''	''	' (' (' (' (
Dane techniczne	NJ Njaca Vth cVdek V[c Bak	%!*	8%#	!%#	%!*	8%#	!%#	%!*	8%#	!%#	!%#
	Prędkość obrotowa biegu jałowego (obr/min)	*) (\$	(\$)	(\$)	(\$)	(\$)	(\$)	(\$)	(\$)	(\$)	(\$)
	BUJ Wtdk	%/	%/	%/	%/	%/	%/	%/	%/	%/	%/
	Uchwyt narzędzia							!# 7rkdc_h nk b hrbm			

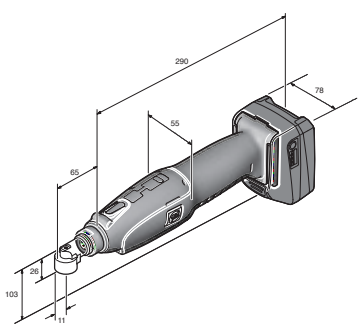

50K %

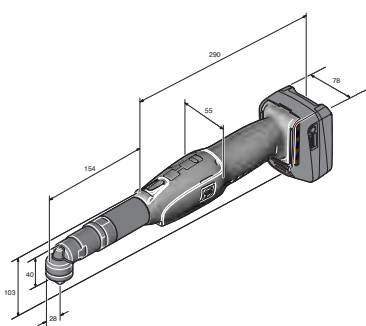

50K %

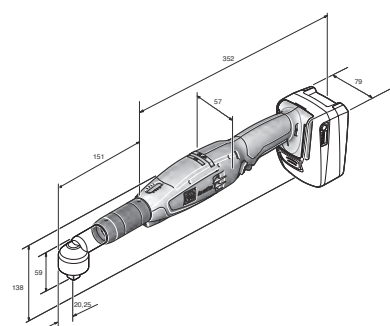

5GK %(!% fWnUj ai UrcU
][yjk]Mh hckYk



5_Vlgc]idUingicbU)

K_f M_UWm]ckUkVg[bcfa :GC)' -' z] 8# 89g (+zkgQ]Mh] 7A? 2% +dimn' %& ik odU/c* g]aU'

NUfNgaca Vdh c]fdekY[c	Ba	%(!*
Df X_c c]fdekU]M]i' t]jkY[c	c]f#a]b	*)\$
Bu]i W	J	%&
Bi a Yf r]La cE]Yb]U		+%&(\$\$\$-) \$
95B		4014586876245
Cena netto (bez VAT) [PK 05]		2.195,60
Cena brutto w PLN [PK 05]		2.700,59

NUYmbUfn Xrj: 9B.

0rg]Mh]ckng]i] YY]h]m]n]i]VkraU]U]W]h
_cb]kU]Y
N]h]k]i]U]R]bca]M]b]Y]d]Y]W]n]i]Y]X]c]U]B]Y]a]c]a]V]d]h
c]f]d]e]k]Y]b]M]U]V]i]V]c]X]c]k]U]k]_k]_f] W]g]U
C]d]h]a]U]i]U]M]f]c]M]g] X]j]_j]o]c]B]i]M]i] d]b]b]k]b]c]
k]y]V]b]i]j]r]U]W]r]d]M]M]i] d]h]X]c]b]b]k]b]r]a] f]o]r]i] W]i]a]
f]c]b]i]c]U]j]i] ai U]e]U'

5]h]k]U]M]c]f]d]e]k] k]_k]c]d]h]h]b]U]i]g] W]d]m]i]j]i]"
H]W]b]c]j]U]j]e]k]d]t]b]k]U]h]M]k]i]U]k]_g]n]_j]M]W] c]d]M]U]Y
b]U]Y]t]r]a] b]i]j]k]k]U]i] U]j] ai U]e]U'
O]n]j]d]f] X]c] c]f]d]e]k]U]c]g]a]Y]c]k]n]g]M]i]g]U
O]n]j]c]k]M]h]i]Y]a]M]g]M]k]_f] W]g]U
8]c]k]_f] W]g]U]a]_][c]H]k]U]X]c]'
U]j]c]k]n]i]o]r]i] W]
7]M]W]k]n]g]M]i]g]U'
6]U]f]c]k]n]g]_j]g]e]d]Y] g]i] H]W]b]c] W]
; y]k]M]W] h]e]k]Y]d]h]i]g]M]k]U]B]Y]k] r]U]f]N]g]Y' *\$S'
Ac]k]c] r]i]g]e]g]k]U]i]b]i]n]X]r]j]r]U]i]g]c]k]n]i]g]

5GK %(!% fWnUj ai UrcU
][yjk]Mh hckYk



Akcesoria, patrz strona 35

Wkretarka certyfikowana według norm ISO 5393, VDI/VE 2647, współczynnik CMK > 1,67 przy ± 10% (w oparciu o 6 sigma).

NUfNgaca Vdh c]fdekY[c	Ba	%&
Df X_c c]fdekU]M]i' t]jkY[c	c]f#a]b)\$
Napiecie	V	14,4
Bi a Yf r]La cE]Yb]U		+%&(\$\$\$-) \$
95B		(%) , * , +& &
7YbU]b]Y]f]c] f]W]n]j] 5H:O? \$]Q		8]%) Z] \$
7YbU]V]i] H]e]k] D]B] O? \$]Q		8]4]\$\$\$) -

NUYmbUfn Xrj: 9B.

0rg]Mh]ckng]i] YY]h]m]n]i]VkraU]U]W]h
_cb]kU]Y
N]h]k]i]U]R]bca]M]b]Y]d]Y]W]n]i]Y]X]c]U]B]Y]a]c]a]V]d]h
c]f]d]e]k]Y]b]M]U]V]i]V]c]X]c]k]U]k]_k]_f] W]g]U
C]d]h]a]U]i]U]M]f]c]M]g] X]j]_j]o]c]B]i]M]i] d]b]b]k]b]c]
k]y]V]b]i]j]r]U]W]r]d]M]M]i] d]h]X]c]b]b]k]b]r]a] f]o]r]i] W]i]a]
f]c]b]i]c]U]j]i] ai U]e]U'

5]h]k]U]M]c]f]d]e]k] k]_k]c]d]h]h]b]U]i]g] W]d]m]i]j]i]"
H]W]b]c]j]U]j]e]k]d]t]b]k]U]h]M]k]i]U]k]_g]n]_j]M]W] c]d]M]U]Y
b]U]Y]t]r]a] b]i]j]k]k]U]i] U]j] ai U]e]U'
O]n]j]d]f] X]c] c]f]d]e]k]U]c]g]a]Y]c]k]n]g]M]i]g]U
O]n]j]c]k]M]h]i]Y]a]M]g]M]k]_f] W]g]U
8]c]k]_f] W]g]U]a]_][c]H]k]U]X]c]'
U]j]c]k]n]i]o]r]i] W]
7]M]W]k]n]g]M]i]g]U'
6]U]f]c]k]n]g]_j]g]e]d]Y] g]i] H]W]b]c] W]
; y]k]M]W] h]e]k]Y]d]h]i]g]M]k]U]B]Y]k] r]U]f]N]g]Y' *\$S'
Ac]k]c] r]i]g]e]g]k]U]i]b]i]n]X]r]j]r]U]i]g]c]k]n]i]g]

5GK %(!% fWnUj ai UrcU
][yjk]Mh hckYk



5_Vlgc]idUingicbU)

K_f M_UWm]ckUkVg[bcfa :GC)' -' z] 8# 89g (+zkgQ]Mh] 7A? 2% +dimn' %& ik odU/c* g]aU'

NUfNgaca Vdh c]fdekY[c	Nm	!%&
Df X_c c]fdekU]M]i' t]jkY[c	c]f#a]b	(\$\$
Bu]i W	J	%&
Bi a Yf r]La cE]Yb]U		+%&(\$\$\$-) \$
95B		(%) , * , +& &
7YbU]b]Y]f]c] f]W]n]j] 5H:O? \$]Q		8]%) Z] \$
7YbU]V]i] H]e]k] D]B] O? \$]Q		8]4]\$\$\$) -

NUYmbUfn Xrj: 9B.

0rg]Mh]ckng]i] YY]h]m]n]i]VkraU]U]W]h
_cb]kU]Y
N]h]k]i]U]R]bca]M]b]Y]d]Y]W]n]i]Y]X]c]U]B]Y]a]c]a]V]d]h
c]f]d]e]k]Y]b]M]U]V]i]V]c]X]c]k]U]k]_k]_f] W]g]U
C]d]h]a]U]i]U]M]f]c]M]g] X]j]_j]o]c]B]i]M]i] d]b]b]k]b]c]
k]y]V]b]i]j]r]U]W]r]d]M]M]i] d]h]X]c]b]b]k]b]r]a] f]o]r]i] W]i]a]
f]c]b]i]c]U]j]i] ai U]e]U'

5]h]k]U]M]c]f]d]e]k] k]_k]c]d]h]h]b]U]i]g] W]d]m]i]j]i]"
H]W]b]c]j]U]j]e]k]d]t]b]k]U]h]M]k]i]U]k]_g]n]_j]M]W] c]d]M]U]Y
b]U]Y]t]r]a] b]i]j]k]k]U]i] U]j] ai U]e]U'
O]n]j]d]f] X]c] c]f]d]e]k]U]c]g]a]Y]c]k]n]g]M]i]g]U
O]n]j]c]k]M]h]i]Y]a]M]g]M]k]_f] W]g]U
8]c]k]_f] W]g]U]a]_][c]H]k]U]X]c]'
U]j]c]k]n]i]o]r]i] W]
7]M]W]k]n]g]M]i]g]U'
6]U]f]c]k]n]g]_j]g]e]d]Y] g]i] H]W]b]c] W]
; y]k]M]W] h]e]k]Y]d]h]i]g]M]k]U]B]Y]k] r]U]f]N]g]Y' *\$S'
Ac]k]c] r]i]g]e]g]k]U]i]b]i]n]X]r]j]r]U]i]g]c]k]n]i]g]

5GK %!\$ D7 fWnUj ai UtefU][jck]Mh hckYk

D7c[rLackUkUk_f M_Uhac]kc V\W\h\Uj\k[:cC)' -' z] 8# 89# (+zkgUjVhd] 7A? 2% +dirm+ %



5_Vjg[r]zdUing]cbU)

Njfnjaca Vh c'fdekV[c	Ba	%!*
D7 Xc c'fdekUjM]i 'tjckV[c	c'f#a]b)\$+\$\$
Napiecie	V	14,4
Bi a Yf rLb CE]Yb]U		+)%&)\$\$\$-) \$
95B		(\$%) , * , +(88%
7YbUbVhc fWnJ 5H:0D? \$)Q		8%, -Z \$
7YbUVi Hck D8B 0D? \$)Q		'(' %88%

NUYmbUfn Xrj]: 98.
 > 6'rgUhd]cknig]t] YVjHnMn]n]VkraUjUWb]dg]kUjV
 Ac]kc n]fcd[rLackUj]dU]hV]CE. d' Xc W
 c'fdekYz]mi b] c'fcdkZz]nc'fch]zaca Vh
 c'fdekV[c]d'c]]VWj"
 CdmaUjUWfcd]k d] W_fc UWd'c[rbi
 i gk]Ubn]b]h]Uj]Yc]U]h]Uj]Vg]h]UjV
 I gk]Uj]_f]r]Uj]Y]X]E k]pi V]a' ac]c 'a]U]i UjV
 H]W]b]c]U]j]ek]d'eb]k]U]h]k]b]k]_g]]M' c]M]UjV
 b]U]h]na b]j]ck]U]j Uj ai UtefU
 Ach jg]k]j]k]n]i]M]U]_f V]b]V]_f h]j]r]U]j]_Y
 d]U]h V]i]n]U]U]UjV
 U]k]Y]k]d]c]k]U]h]U]j]V]U]h]M]d]h]n]_c]ad M'
 6'rd]M]b]V]d]c[r]LackU]j]i f]n]X]h]j]U]b]d]h]n]i
 r]h]f]c]k]U]b]r]y]M'
 N]d]g]h]U]j]d]U]h V]CE
 8ck_f V]U]j]a]]_]c]H]k]U]M]c'
 6'U]_g]U]j] c'fcdkZz c]b]W]j]k_f V]U]j]U]j]_j]g]f]c]k]U]j
 V]f]t]j]a"
 :U]h]M]b]V]r]U]W]r]U]M]E]V]U]j]a"
 Ach]M]U]j ai Utef]ek]d'eb]k]n]i]V]kg]U]b]]a'
 b]j]ck]U]jV
 ; j]k]M]Z]ek]Y]d]h]g]k]U]b]V]k r]U]f]g]V' *\$S'
 Ac]kc n]f]g]g]k]U]j]U]b]n]X]r]j]U]j]d]ck]n]i

5GK %!\$ D7 fWnUj ai UtefU][jck]Mh hckYk

D7c[rLackUkUk_f M_Uhac]kc V\W\h\Uj\k[:cC)' -' z] 8# 89# (+zkgUjVhd] 7A? 2% +dirm+ %



5_Vjg[r]zdUing]cbU)

Njfnjaca Vh c'fdekV[c	Ba	8%\$
D7 Xc c'fdekUjM]i 'tjckV[c	c'f#a]b)\$+\$\$
Bu] V]V	J	%Z
Bi a Yf rLb CE]Yb]U		+)%&)\$\$\$-) \$
95B		(\$%) , * , +(88+
7YbUbVhc fWnJ 5H:0D? \$)Q		8%, -Z \$
7YbUVi Hck D8B 0D? \$)Q		'(' %88%

NUYmbUfn Xrj]: 98.
 > 6'rgUhd]cknig]t] YVjHnMn]n]VkraUjUWb]dg]kUjV
 Ac]kc n]fcd[rLackUj]dU]hV]CE. d' Xc W
 c'fdekYz]mi b] c'fcdkZz]nc'fch]zaca Vh
 c'fdekV[c]d'c]]VWj"
 CdmaUjUWfcd]k d] W_fc UWd'c[rbi
 i gk]Ubn]b]h]Uj]Yc]U]h]Uj]Vg]h]UjV
 I gk]Uj]_f]r]Uj]Y]X]E k]pi V]a' ac]c 'a]U]i UjV
 H]W]b]c]U]j]ek]d'eb]k]U]h]k]b]k]_g]]M' c]M]UjV
 b]U]h]na b]j]ck]U]j Uj ai UtefU
 Ach jg]k]j]k]n]i]M]U]_f V]b]V]_f h]j]r]U]j]_Y
 d]U]h V]i]n]U]U]UjV
 U]k]Y]k]d]c]k]U]h]U]j]V]U]h]M]d]h]n]_c]ad M'
 6'rd]M]b]V]d]c[r]LackU]j]i f]n]X]h]j]U]b]d]h]n]i
 r]h]f]c]k]U]b]r]y]M'
 N]d]g]h]U]j]d]U]h V]CE
 8ck_f V]U]j]a]]_]c]H]k]U]M]c'
 6'U]_g]U]j] c'fcdkZz c]b]W]j]k_f V]U]j]U]j]_j]g]f]c]k]U]j
 V]f]t]j]a"
 :U]h]M]b]V]r]U]W]r]U]M]E]V]U]j]a"
 Ach]M]U]j ai Utef]ek]d'eb]k]n]i]V]kg]U]b]]a'
 b]j]ck]U]jV
 ; j]k]M]Z]ek]Y]d]h]g]k]U]b]V]k r]U]f]g]V' *\$S'
 Ac]kc n]f]g]g]k]U]j]U]b]n]X]r]j]U]j]d]ck]n]i

5GK %!\$ D7 fWnUj ai UtefU][jck]Mh hckYk

D7c[rLackUkUk_f M_Uhac]kc V\W\h\Uj\k[:cC)' -' z] 8# 89# (+zkgUjVhd] 7A? 2% +dirm+ %



5_Vjg[r]zdUing]cbU)

Njfnjaca Vh c'fdekV[c	Ba	'!%\$
D7 Xc c'fdekUjM]i 'tjckV[c	c'f#a]b	50-530
Bu] V]V	J	%Z
Bi a Yf rLb CE]Yb]U		+)%&)\$\$\$-) \$
95B		(\$%) , * , +(8(
7YbUbVhc fWnJ 5H:0D? \$)Q		8%, -Z \$
7YbUVi Hck D8B 0D? \$)Q		'(' %88%

NUYmbUfn Xrj]: 98.
 > 6'rgUhd]cknig]t] YVjHnMn]n]VkraUjUWb]dg]kUjV
 Ac]kc n]fcd[rLackUj]dU]hV]CE. d' Xc W
 c'fdekYz]mi b] c'fcdkZz]nc'fch]zaca Vh
 c'fdekV[c]d'c]]VWj"
 CdmaUjUWfcd]k d] W_fc UWd'c[rbi
 i gk]Ubn]b]h]Uj]Yc]U]h]Uj]Vg]h]UjV
 I gk]Uj]_f]r]Uj]Y]X]E k]pi V]a' ac]c 'a]U]i UjV
 H]W]b]c]U]j]ek]d'eb]k]U]h]k]b]k]_g]]M' c]M]UjV
 b]U]h]na b]j]ck]U]j Uj ai UtefU
 Ach jg]k]j]k]n]i]M]U]_f V]b]V]_f h]j]r]U]j]_Y
 d]U]h V]i]n]U]U]UjV
 U]k]Y]k]d]c]k]U]h]U]j]V]U]h]M]d]h]n]_c]ad M'
 6'rd]M]b]V]d]c[r]LackU]j]i f]n]X]h]j]U]b]d]h]n]i
 r]h]f]c]k]U]b]r]y]M'
 N]d]g]h]U]j]d]U]h V]CE
 8ck_f V]U]j]a]]_]c]H]k]U]M]c'
 6'U]_g]U]j] c'fcdkZz c]b]W]j]k_f V]U]j]U]j]_j]g]f]c]k]U]j
 V]f]t]j]a"
 :U]h]M]b]V]r]U]W]r]U]M]E]V]U]j]a"
 Ach]M]U]j ai Utef]ek]d'eb]k]n]i]V]kg]U]b]]a'
 b]j]ck]U]jV
 ; j]k]M]Z]ek]Y]d]h]g]k]U]b]V]k r]U]f]g]V' *\$S'
 Ac]kc n]f]g]g]k]U]j]U]b]n]X]r]j]U]j]d]ck]n]i

5GK %!' \$D7 fWnUj ai UcfU Df[rLackUk_f M_Uhac]kc V\W\H\U\K[:GC)' -' zJ 8# 89# (+zkgQ\WbJ 7A? 2%+dim+ %

fk cdM/c* g'ale'



5_VgcfJzdUingfcbU)

Nj\Ngaca Vbi c'fdekV[c	Ba	%' \$
Df X_c c'fdekU\Nj' t'jkV[c	c\#a]b	## \$
Bu] W	J	%Z
I WkrHbLn X]J		' # '7rkfc_ h rkb hrtm
Bi a Yf rLa CR]Yb]J		+%%)' '\$-)' \$
95B		(\$Q, *, +)' (-)
7YbUbyHtc fWnJ 5H:O? \$)Q		** +)' Z' \$
7YbUVri Htc D#B O? \$)Q		+)' (%-)

NUYmbLfn Xrj: 98.

'@rg\Wb]ckn]t] Y\j\H\Wb]n]k\raU\W\cb]g]kU\Y
'Ac]kc r\fc[rLackU]j\U]a]V\CE. d' X_c W
'c'fdekYz]m] b] c'fckEz_ r\c'fch]zaca Vbi
'c'fdekV[c'd]c]]Wg]"
'CdmaU]W\c'fck] k d] W_fc_U\Wd]c[r]ai
'i g]k]U]r]a]b]h]M U]j]Yc_U]a]U]b]Y]g]h]U]Y
'I g]k]U]Y_f]r]M]U]Y]Y]C] k]r]i] W]a]c]kc 'a]U]b] U]Y
'H\W]b]c]U]j]k]c]d]e]b]k]U]h]M]k]t]k]]_g]]M] c'd]M]U]Y
'U]Y]W]ra b]j]ck]U]j U]j ai U]e]U
'Ac] j]g]k]t]k]n]M]U]k_f V]b]Y]k_f h]j]r]U]j] Y
'd]U]a V]r]j]U]M]U]Y
'U]k]Y]k]d]c]k]U]h]U]j]Y]U]r]a]d]r]h]_c]ad]P]"
'@r]M]W]b]c]d]e]f]g]h]i]j]k]l]m]n]o]p]q]r]s]t]u]v]w]x]y]z]A]
'r]h]i]j]k]l]m]n]o]p]q]r]s]t]u]v]w]x]y]z]A]
'N]U]j]g]h]i]j]k]l]m]n]o]p]q]r]s]t]u]v]w]x]y]z]A]
'B]c]k_f W]g]U]a]]_M]c]H]k]U]X]c]"
'@]U]g]U]X]j c'fckE c]b]W]g]k_f W]g]U]j]]_g]m]ck]U]j
'W]t]]a]"
' :U]r]a]b]Y]r]U]W]r]j]M]W]j]V]U]j]a]"
'Ac]U]r]j ai U]e]]k]c]d]e]b]k]n]i]k]g]U]b]]a b]j]ck]U]j
' ; j]k]M]_ k]k]Y]d]r]g]k]U]Y]k] r]U]r]g]V' *\$S'
' Ac]kc r]U]g]g]k]U]j]U]b]n]X]j]r]U]j]c]k]n]r]

5GK %!' \$D7 fWnUj ai UcfU]]j]k]M]h_ k]k]Y]k

Programowana wkrętarka z możliwością certyfikacji wg ISO 5393, VDI/VDE 2647, współczynnik CMK > 1,67 przy ± 10%



5_VgcfJzdUingfcbU)

Nj\Ngaca Vbi c'fdekV[c	Nm	-30
Df X_c c'fdekU\Nj' t'jkV[c	c\#a]b)\$(\$
Bu] W	J	%
Bi a Yf rLa CR]Yb]J		+%%*&* '\$\$\$
95B		(\$Q, *, ', ') \$
7YbUbyHtc fWnJ 5H:O? \$)Q		(') \$\$\$
7YbUVri Htc D#B O? \$)Q		(') ", \$

NUYmbLfn Xrj: 98.

'@rg\Wb]ckn]t] Y\j\H\Wb]n]k\raU\W\cb]g]kU\Y
'Df[rLackU]r]k]g]U]b]]_j]c]t]U]k a]U]r]t]j]"
'Ac]kc r\fc[rLackU]j\U]a]V\CE. d' X_c W
'c'fdekYz]m] b] c'fckEz_ r\c'fch]zaca Vbi
'c'fdekV[c'd]c]]Wg]"
'CdmaU]W\c'fck] k d] W_fc_U\Wd]c[r]ai
'i g]k]U]r]a]b]h]M U]j]Yc_U]a]U]b]Y]g]h]U]Y
'H\W]b]c]U]j]k]c]d]e]b]k]U]h]M]k]t]k]]_g]]M] c'd]M]U]Y
'U]Y]W]ra b]j]ck]U]j U]j ai U]e]U
'Ac] j]g]k]t]k]n]M]U]k_f V]b]Y]k_f h]j]r]U]j] Y
'd]U]a V]r]j]U]M]U]Y
'U]k]Y]k]d]c]k]U]h]U]j]Y]U]r]a]d]r]h]_c]ad]P]"
'N]U]j]g]h]i]j]k]l]m]n]o]p]q]r]s]t]u]v]w]x]y]z]A]
'B]c]k_f W]g]U]a]]_M]c]H]k]U]X]c]"
'@]U]g]U]X]j c'fckE c]b]W]g]k_f W]g]U]j]]_g]m]ck]U]j
'W]t]]a]"
' :U]r]a]b]Y]r]U]W]r]j]M]W]j]V]U]j]a]"
'Ac]U]r]j ai U]e]]k]c]d]e]b]k]n]i]k]g]U]b]]a
b]j]ck]U]j
' ; j]k]M]_ k]k]Y]d]r]g]k]U]Y]k] r]U]r]g]V' *\$S'
' Ac]kc r]U]g]g]k]U]j]U]b]n]X]j]r]U]j]c]k]n]r]

5GK %!() D7 fWnUj ai UcfU]]j]k]M]h_ k]k]Y]k

Zalety narzędzi FEIN:



5_VgcfJzdUingfcbU)

Nj\Ngaca Vbi c'fdekV[c	Ba	!()
Df X_c c'fdekU\Nj' t'jkV[c	c\#a]b)\$!' \$
Napięcie	V	%
Numer zamówienia		7 112 63 60 00 0
95B		(\$Q, *, ', ' , (+
7YbUbyHtc fWnJ 5H:O? \$)Q		(') (\$\$\$
7YbUVri Htc D#B O? \$)Q		(') !)' \$\$\$

Zalety narzędzi FEIN:

'@rg\Wb]ckn]t] Y\j\H\Wb]n]k\raU\W\cb]g]kU\Y
'_cb]g]kU\Y
'Df[rLackU]r]k]g]U]b]]_j]c]t]U]k a]U]r]t]j]"
'Ac]kc r\fc[rLackU]j\U]a]V\CE. d' X_c W
'c'fdekYz]m] b] c'fckEz_ r\c'fch]zaca Vbi
'c'fdekV[c'd]c]]Wg]"
'CdmaU]W\c'fck] k d] W_fc_U\Wd]c[r]ai
'i g]k]U]r]a]b]h]M U]j]Yc_U]a]U]b]Y]g]h]U]Y
'H\W]b]c]U]j]k]c]d]e]b]k]U]h]M]k]t]k]]_g]]M] c'd]M]U]Y
'U]Y]W]ra b]j]ck]U]j U]j ai U]e]U
'Ac] j]g]k]t]k]n]M]U]k_f V]b]Y]k_f h]j]r]U]j] Y
'd]U]a V]r]j]U]M]U]Y
'U]k]Y]k]d]c]k]U]h]U]j]Y]U]r]a]d]r]h]_c]ad]P]"
'N]U]j]g]h]i]j]k]l]m]n]o]p]q]r]s]t]u]v]w]x]y]z]A]
'B]c]k_f W]g]U]a]]_M]c]H]k]U]X]c]"
'@]U]g]U]X]j c'fckE c]b]W]g]k_f W]g]U]j]]_g]m]ck]U]j
'W]t]]a]"
' :U]r]a]b]Y]r]U]W]r]j]M]W]j]V]U]j]a]"
'Ac]U]r]j ai U]e]]k]c]d]e]b]k]n]i]k]g]U]b]]a
b]j]ck]U]j
' ; j]k]M]_ k]k]Y]d]r]g]k]U]Y]k] r]U]r]g]V' *\$S'
' Ac]kc r]U]g]g]k]U]j]U]b]n]X]j]r]U]j]c]k]n]r]

ASW 18-60 PC (bez akumulatora i głowicy kątowej)



5_VWfJidUingidU)

Dfc]rLackUlk_f M_Uhac]kc V\W\W\U\k[: :C) ' -' z] 8# 89# (+zkg]Q\Wd] 7A? 2% +d]m+ %& " fK cdM/c* g]aU'

Zakres momentu obrotowego	Ba	!*\$
Df Xc c]fcdkU\W]i 'tjkcY[c	c]f#]b)\$&\$
Bu] W	J	%
Bi a Yr]l]a Ck]M]jU	+%&* (*\$ \$&\$	
95B	4014586883854	
Cena netto (bez VAT) [PK 05]	5.060,00	
Cena brutto w PLN [PK 05]	6.223,80	

NUYmbUfn Xrj]: 9B.
 'G]ng]W]d]ckn]g]i] YV]h]m]b]n]g]YkraU]U]Vh
 _cd]g]k]U]Y
 Dfc]rLackUln]g]U]h] n]j]f]h] Uk a]U]n]g]i]'
 'Ac]kc r]m]c]r]LackU]j]U]b]U]b]V]i]C]e. d]f X]c W
 c]fcdkY]Z_]M]i b]j c]fcdk]E]Z_ N]U]f]h]Z]aca V]h
 c]fcdkY[c]d]f]c]i]]W]g]"
 'C]d]m]U]h]U]M]c]f]m]g] k d] W]_f]c]U]M]d]c]r]l]a i
 i]g]k]U]b]n]M]b]h]M]U]j]Y]c]U]j]a]U]b]Y]g]h]U]Y
 'H]W]b]c]c]U]j]e]k]d]t]b]c]k]U]h]M]k]U]k]_g]]M]W' c]d]M]U]Y
 b]U]W]b]n]a b]j]p]c]k]U]j] U]j ai UedU
 'Ac]h] j]g]k]U]j]k]n]i]M]U]k_f V]b]Y]k_f h]n]j]r]l]g]Y
 c]f]l]a V]h]n]U]U]Y
 'U]k]Y]k]d]c]k]U]h]U]j]Y]U]b]n]M]d]n]_c]ad P]f'
 'N]d]j]g]h]U]j]Y]c]f]l]a V]i]C]e
 'S]c]k_f W]g]U]a]_]]c]k]U]M]c]'
 'Z]U]g]U]j] c]fcdk]E] c]b]M]g]k_f W]g]U]h]_]g]m]c]k]U]j'
 W]t]j]a]"
 ': U]h]n]b]Y]r]U]W]n]Q]W]E]j]V]U]j]a]"
 'Ac]U]h]j] ai Ued]e]k]d]t]b]c]k]n]i]V]k]g]U]h]]n]a'
 b]j]p]c]k]U]j]
 ; j]k]M]W_ k]e]Y]d]n]g]k]U]b]Y]k] n]U]V]g]Y' *\$&
 'Ac]kc r]m]c]g]k]U]j]U]b]n]X]r]j]U]j]c]k]n]g]

: 9B AccuTec

K n]d]o]g]U] Y]b]j]Y]c]C]B]Y



5_j ai Uedf @]e]k]d]t]b]c]k]n]i]V]k]g]U]h]]n]a]g]M]i b]j]p]c]k]U]j]U

Bu] W	D]c]Y]abc	Bi a Yr]l]a Ck]M]jU	7]V]b]U]b]M]e	7]V]b]U]h]i]e
J	S]		f]W]h]U] S]E	k] D]E]B
%&A<	2	- \$& \$ (\$& \$&)	' - %& \$	(, %& +
%&B]A<)	- \$& \$ (%& \$& \$))& Z \$	* ((\$
%	2,5	9 26 04 171 02 0	435,60	535,79
%)	- \$& \$ (%& \$& \$)	* -- Z \$, * \$ %

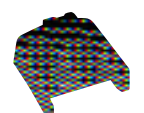

5X]U]h]V] X]c]j]Y]k]c]k]U]f_] do z]l]z]aca akumulatora NiCd i NiMH na ALS 40, ALG 40 i ALG 30.

Numer zamówienia	Cena netto	7]V]b]U]h]i]e
- \$& \$ (%& \$& \$)	f]W]h]U] S]E	k] D]E]B
	** \$& \$, %& p



F U]b]n]d]f]n]Y]U]b]]a]c]a Y]h]i c]f]c]d]c]k]U]f]c

Bi a Yr]l]a Ck]M]jU	7]V]b]U]b]M]e	7]V]b]U]h]i]e
' \$& \$ (\$& \$)	f]W]h]U] S]E	k] D]E]B
	32,80	40,34



5_j ai Uedf

Bu] W	D]c]Y]abc	Bi a Yr]l]a Ck]M]jU	7]V]b]U]b]M]e	7]V]b]U]h]i]e
J	S]		f]W]h]U] S]E	k] D]E]B
- Z B]A<	2	- \$& \$ (\$& \$&))& Z \$	* (- Z (
%&B]A<	&	- \$& \$ (\$& \$ +)) + Z \$	+ \$ Z +
%&B]A<	\$	- \$& \$ (\$ + \$& %)	+ - Z \$	- \$ Z \$

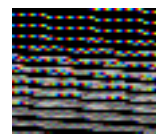

D]c]_f]c]k]]W]W]U]j] ai 'Uedf X]c]c]U]f]c]d]n]e]b]k]]M]r]W]g]c]U]U]j]U]b]n]M]d]n]V]a]]P]C]E] d]n]V]k i]g]n]c]h]k]]a] W]W]E]]M]b]n]a] X]c]U]j] ai UedU]e]k]d]t]b]c]k]U]f]c' (J & # \$) S

Bi a Yr]l]a Ck]M]jU	7]V]b]U]b]M]e	7]V]b]U]h]i]e
' \$& \$ (\$& \$)	f]W]h]U] S]E	k] D]E]B
	* + Z \$, \$& \$

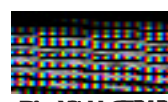

U]U]k]c]k]U]f_U]5@G(\$ @]h]_U]U]h]U]U]V]i]c'

Bi a Yr]l]a Ck]M]jU	7]V]b]U]b]M]e	7]V]b]U]h]i]e
- \$& \$ (%& \$& \$)	f]W]h]U] S]E	k] D]E]B
	*) & Z \$, \$ %& \$

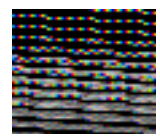

D]c]_f]c]k]]W]W]U]j] ai 'Uedf X]c]c]U]f]c]d]n]e]b]k]]M]r]W]g]c]U]U]j]U]b]n]M]d]n]V]a]]P]C]E] d]n]V]k i]g]n]c]h]k]]a] W]W]E]]M]b]n]a] X]c]U]j] ai UedU]e]k]d]t]b]c]k]U]f]c' (J (#) S

Bi a Yr]l]a Ck]M]jU	7]V]b]U]b]M]e	7]V]b]U]h]i]e
' \$& \$ (\$& \$)	f]W]h]U] S]E	k] D]E]B
	+ %& \$, , Z (



Q]m]V_U]j]Y]k]c]k]U]f_U]5@ (\$ Q]m]f]c]k]U]U]f]c]d]n]g]_f]n]a]Z]W]g]j]p]d]c]k]U]j]c_' \$& \$ a]b] k] n]U]Y] b]c] V]W]X]U]j] ai UedU]e]k]d]t]b]c]k]U]f]c' \$& \$ K Z]W]U]f] \$& \$ _]'

Bi a Yr]l]a Ck]M]jU	7]V]b]U]b]M]e	7]V]b]U]h]i]e
- \$& \$ (%& \$& \$)	f]W]h]U] S]E	k] D]E]B
	* * * Z \$	+ - Z'

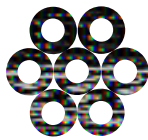

H YV_cX ^W
Xc_cfdkY[c'ntuWqkUjBCE

:LWU	QW	Bi aYrLbCE]MjU	7YbUblle' (bez VAT)	Cena brutto w PLN
kolory mieszane	+	' \$ % 0 \$ \$ \$	(' \$ \$) \$ -	
h]W]g]	%	' \$ % (, \$/ \$) + \$ \$	+ \$ \$
W]kcdU	%	' \$ % (- \$/ \$) + \$ \$	+ \$ \$
dzaUUVkrm	%	' \$ %) \$ \$ \$		57,60 70,85
zóty	%	' \$ %) \$ \$ \$) + \$ \$	+ \$ \$
g]U	%	' \$ % (* \$/ \$) + \$ \$	+ \$ \$
r]y dcm	%	' \$ % (+ \$/ \$) + \$ \$	+ \$ \$
W]bU	10	3 05 01 352 01 0) + \$ \$	+ \$ \$

K ndcGJ Yb]YXcXUj_cK Y 5GA

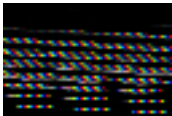

Dc_fck]W]5771 H7 5GA
Xc_cWfdnck]M]r]W]c]U]U]b]r]U]d]n]V]a]j]B]C]E] d]n]X
i]g]n]c]h]b]j]a]W]W]j]M]b]r]a]

Bi aYrLbCE]MjU	7YbUblle' (bez VAT)	7YbUblle' k DEB
' % \$ \$ \$ \$ \$, \$ \$	-- \$,



Uchwyt do wkrętarki ASM/ASSm
I Wkrhckgrh]WacV]: 98 5771 H7 5GA] 5Gaa"

Bi aYrLbCE]MjU	7YbUblle' (bez VAT)	Cena brutto w PLN
' \$ \$ \$ \$ \$ \$ \$	') % \$ \$	(' % ,

K ndcGJ Yb]YXcXUj_cK Y 5GK - #? \$ #? %

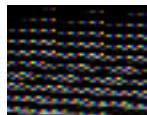

Dc_fck]W]5771 H7 5GK
Xc_cWfdnck]M]r]W]c]U]U]b]r]U]d]n]V]a]j]B]C]E] d]n]X
i]g]n]c]h]b]j]a]W]W]j]M]b]r]a]

Bi aYrLbCE]MjU	7YbUblle' (bez VAT)	Cena brutto w PLN
3 21 74 014 01 0	67,40	82,90



; yck]W_ hckU6UjW

I WkrhUlnXjU	Bi aYrLbCE]MjU	7YbUblle' (bez VAT)	7YbUblle' k DEB
% ("OY]V]_ HkYkb H]r]n]E]i]M]B	- \$/ \$ \$ \$ \$ \$ \$	% \$) \$ \$	\$ % - \$ -
' # "7rkdc_ H]r]k]b] H]r]m	- \$/ \$ \$ \$ \$ \$ \$	% \$) \$ \$	\$ % - \$ -
% ("7rkdc_ H]r]k]b] H]r]m	- \$/ \$ \$ \$ \$ \$ \$	% \$) \$ \$	\$ % - \$ -



Dc_frkUcW]f]c]b]b]U]n]k]c]f]r]k]U]g]h]i]V]b]Y]c
Xc_cWfdnck]M]r]W]c]U]U]b]r]U]d]n]V]a]j]B]C]E] d]n]X
i]g]n]c]h]b]j]a]W]W]j]M]b]r]a]

Bi aYrLbCE]MjU	7YbUblle' (bez VAT)	7YbUblle' k DEB
' % \$ % * \$ \$ \$, \$ \$	' % +



5XU]H]V] a]c]U] ^]W]X]c] [y]k]M]h]_ h]c]Y] ^
n]_k]U]r]U]k]_ c] V]E]_ % ("X]c]r]L]_h]_ h]m] [f]c]K]E] '
^m]p]k]r]U]@]W]W]j] [b]U]U]H]V] 5]z]h]g]c]k] d]y]W]E]j] '
n] [y]k]M]_ h]c] D]V]a]] a]"

Bi aYrLbCE]MjU	7YbUblle' (bez VAT)	7YbUblle' k DEB
* ' - \$/ \$ (* \$ \$ \$	' % * \$ \$	' % \$,

5_Wg:]U]X]c] a]c]X]Y] D]U]L]a] V]H] 7]c]b]f]c



5XU]H]V] X]c] d]f]c] [f]L]a] c]k]U]j]U
8]c]k]g]r]h]]W]a]c]V]]A]7]7] H]7] D]U]L]a] V]H] 7]c]b]f]c] "K] r]g]n]k]Y] '
C]d]f] [f]L]a] c]k]U]j]U]]U]]U]]M] G]c]d]U]]b]g]e]_]W]a]c]V]] [b]U]U]H]V] '
]d]n]k]C]d]m]j]W]E]j]k]r]h]

Bi aYrLbCE]MjU	7YbUblle' (bez VAT)	7YbUblle' k DEB
- \$ \$ (% ' \$ \$ \$	% \$ \$ \$	% - + \$